



ETA-Danmark A/S  
Göteborg Plads 1  
DK-2150 Nordhavn  
Tel. +45 72 24 59 00  
Internet [www.etadanmark.dk](http://www.etadanmark.dk)

Authorised and notified according  
to Article 29 of the Regulation (EU)  
No 305/2011 of the European  
Parliament and of the Council of 9  
March 2011

MEMBER OF EOTA



## European Technical Assessment ETA-13/0090 of 2025/03/03

### I General Part

**Technical Assessment Body issuing the ETA and designated according to Article 29 of the Regulation (EU) No 305/2011: ETA-Danmark A/S**

**Trade name of the construction product:**

NOVA self-tapping screws

**Product family to which the above construction product belongs:**

Screws for use in timber constructions

**Manufacturer:**

Nova. Fastener Co., Ltd.  
No. 6, Ln. 68 Da-Pu 2<sup>nd</sup> St.,  
Kangshan Kaohsiung, Taiwan (R.O.C)  
Tel. +886-7-6281825  
Fax.+886-7-6284111  
Internet: [www.novafastener.com.tw](http://www.novafastener.com.tw)

**Manufacturing plant:**

Nova. Fastener Co., Ltd.

**This European Technical Assessment contains:**

30 pages including 3 annexes which form an integral part of the document

**This European Technical Assessment is issued in accordance with Regulation (EU) No 305/2011, on the basis of:**

EAD 130118-01-0603, Screws and threaded rods for use in timber constructions.

**This version replaces:**

The previous ETA with the same number issued on 2016-05-19

Translations of this European Technical Assessment in other languages shall fully correspond to the original issued document and should be identified as such.

Communication of this European Technical Assessment, including transmission by electronic means, shall be in full (excepted the confidential Annex(es) referred to above). However, partial reproduction may be made, with the written consent of the issuing Technical Assessment Body. Any partial reproduction has to be identified as such.

## II SPECIFIC PART OF THE EUROPEAN TECHNICAL ASSESSMENT

### 1 Technical description of product

#### Technical description of the product

Nova Fastener screws are self-tapping screws to be used in timber structures. Nova Fastener screws shall be threaded over a part of the length, or over the full length. The screws shall be produced from carbon or stainless (1.4006, 1.4301 or 1.4567) steel wire. Where corrosion protection is required, the material or coating shall be declared in accordance with the relevant specification given in Annex A of EN 14592.

#### Geometry and Material

The nominal diameter (outer thread diameter),  $d$ , shall not be less than 3,5 mm and shall not be greater than 12,0 mm. The overall length,  $L$ , of screws shall not be less than 30 mm and shall not be greater than 400 mm. Other dimensions are given in Annex A.

The ratio of inner thread diameter to outer thread diameter  $d_i/d$  ranges from 0,56 to 0,83.

The screws are threaded over a minimum length  $\ell_g$  of  $4 \cdot d$  (i.e.  $\ell_g \geq 4 \cdot d$ ).

The lead  $p$  (distance between two adjacent thread flanks) ranges from  $0,35 \cdot d$  to  $1,00 \cdot d$ .

The screws covered by this ETA have a minimum bending angle,  $\alpha$ , of  $(45/d^{0,7} + 20)$  degrees.

### 2 Specification of the intended use(s) in accordance with the applicable European Assessment Document (hereinafter EAD)

The screws are used for connections in load bearing timber structures between members of solid timber (softwood), glued laminated timber, cross-laminated timber, and laminated veneer lumber, similar glued members, wood-based panels or steel.

Furthermore NOVA screws with diameters of at least 6 mm may also be used for the fixing of thermal insulation on rafters.

Steel plates and wood-based panels except solid wood panels, laminated veneer lumber and cross laminated timber shall only be located on the side of the screw head. The following wood-based panels may be used:

- Plywood according to EN 636 or ETA
- Particleboard according to EN 312 or ETA
- Oriented Strand Board according to EN 300 or ETA
- Fibreboard according to EN 622-2 and 622-3 or ETA (minimum density 650 kg/m<sup>3</sup>)
- Cement bonded particleboard according to ETA
- Solid wood panels according to EN 13353 and EN 13986 and cross laminated timber according to ETA
- Laminated Veneer Lumber according to EN 14374 or ETA
- Engineered wood products according to ETA; if the ETA of the product includes provisions for the use of self-tapping screws, the provisions of the ETA of the engineered wood product apply

The screws shall be driven into the wood without pre-drilling or after pre-drilling with a diameter not larger than the inner thread diameter for the length of the threaded part and with a maximum of the smooth shank diameter for the length of the smooth shank.

The screws are intended to be used in timber connections for which requirements for mechanical resistance and stability and safety in use in the sense of the Basic Works Requirements 1 and 4 of Regulation 305/2011 (EU) shall be fulfilled.

The design of the connections shall be based on the characteristic load-carrying capacities of the screws. The design capacities shall be derived from the characteristic capacities in accordance with Eurocode 5 or an appropriate national code.

The screws are intended for use for connections subject to static or quasi static loading.

The scope of the screws regarding resistance to corrosion shall be defined according to national provisions that apply at the installation site considering environmental conditions. Section 3.11 of this ETA contains the corrosion protection for NOVA screws made from carbon steel and the material number of the stainless steel.

The provisions made in this European Technical Assessment are based on an assumed intended working life of the hold downs of 50 years.

The indications given on the working life cannot be interpreted as a guarantee given by the producer or Assessment Body, but are to be regarded only as a means for choosing the right products in relation to the expected economically reasonable working life of the works.

### 3 Performance of the product and references to the methods used for its assessment

Characteristic	Assessment of characteristic
<b>3.1 Mechanical resistance and stability*) (BWR1)</b>	
Dimensions	See annex A
Characteristic yield moment	See section 3.4
Bending angle	See section 3.4
Characteristic withdrawal parameter	See section 3.4
Characteristic head pull-trough parameter of screws	See section 3.4
Characteristic tensile strength	Characteristic value $f_{\text{tens},k}$ :
Carbon or stainless (1.4006) steel	d = 3,5 mm: 3,8 kN
	d = 4,0 mm: 5,0 kN
	d = 4,2 mm: 5,5 kN
	d = 4,5 mm: 6,4 kN
	d = 4,8 mm: 7,2 kN
	d = 5,0 mm: 7,9 kN
	d = 6,0 mm: 11 kN
	d = 6,5 mm: 15 kN
	d = 8,0 mm: 20 kN
	d = 8,5 mm: 30 kN
	d = 10,0 mm: 32 kN
	d = 12,0 mm: 38 kN
Stainless (1.4301 or 1.4567) steel	d = 4,2 mm: 3,4 kN
	d = 4,5 mm: 4,8 kN
	d = 4,8 mm: 6,5 kN
	d = 5,0 mm: 5,7 kN
	d = 6,5 mm: 12 kN
Characteristic yield strength	No performance assessed
Characteristic torsional strength	Characteristic value $f_{\text{tor},k}$ :
Carbon or stainless (1.4006) steel	d = 3,5 mm: 2,3 Nm
	d = 4,0 mm: 3,3 Nm
	d = 4,2 mm: 4,0 Nm
	d = 4,5 mm: 4,3 Nm
	d = 4,8 mm: 8,0 Nm
	d = 5,0 mm: 6,5 Nm
	d = 6,0 mm: 11 Nm
	d = 6,5 mm: 14 Nm
	d = 8,0 mm: 30 Nm
	d = 8,5 mm: 35 Nm
	d = 10,0 mm: 44 Nm
	d = 12,0 mm: 65 Nm
	d = 4,2 mm: 3,2 Nm
Stainless (1.4301 or 1.4567) steel	d = 4,5 mm: 3,5 Nm
	d = 4,8 mm: 5,3 Nm
	d = 5,0 mm: 5,3 Nm
	d = 6,5 mm: 12 Nm

Insertion moment	Ratio of the characteristic torsional strength to the mean insertion moment: $f_{\text{tor},k} / R_{\text{tor,mean}} \geq 1,5$
Spacing, end and edge distances of the screws or threaded rods and minimum thickness of the timber material	See annex B
Slip modulus for mainly axially loaded screws and threaded rods	See section 3.4
Durability against corrosion	See section 3.5

### 3.2 Safety in case of fire (BWR2)

Reaction to fire	The screws are made from steel classified as <b>class A1</b> in accordance with EN 13501-1 and Commission Delegated Regulation 2016/364.
------------------	--

\*) See additional information in section 3.4 – 3.6.

### 3.4 Mechanical resistance and stability

The load-carrying capacities for NOVA screws are applicable to the wood-based materials mentioned in paragraph 1 even though the term timber has been used in the following.

The characteristic lateral load-carrying capacities and the characteristic axial withdrawal capacities of NOVA screws should be used for designs in accordance with Eurocode 5 or an appropriate national code.

Point side penetration length must be  $\ell_{\text{ef}} \geq 4 \cdot d$ , where  $d$  is the outer thread diameter of the screw. For the fixing of rafters, point side penetration must be at least 40 mm,  $\ell_{\text{ef}} \geq 40$  mm.

ETAs for structural members or wood-based panels must be considered where applicable.

#### Lateral load-carrying capacity

The characteristic lateral load-carrying capacity of NOVA screws shall be calculated according to EN 1995-1-1:2010 (Eurocode 5) using the outer thread diameter  $d$  as the nominal diameter of the screw. The contribution from the rope effect may be considered.

The characteristic yield moment shall be calculated from:

Carbon or stainless (1.4006) steel

Screw $d = 3,5$ mm:	$M_{y,k} = 2,0$ Nm
Screw $d = 4,0$ mm:	$M_{y,k} = 3,0$ Nm
Screw $d = 4,2$ mm:	$M_{y,k} = 3,2$ Nm
Screw $d = 4,5$ mm:	$M_{y,k} = 4,3$ Nm
Screw $d = 4,8$ mm:	$M_{y,k} = 5,3$ Nm

Screw $d = 5,0$ mm:	$M_{y,k} = 5,9$ Nm
Screw $d = 6,0$ mm:	$M_{y,k} = 9,5$ Nm
Screw $d = 6,5$ mm:	$M_{y,k} = 12$ Nm
Screw $d = 8,0$ mm:	$M_{y,k} = 20$ Nm
Screw $d = 8,5$ mm:	$M_{y,k} = 30$ Nm
Screw $d = 10,0$ mm:	$M_{y,k} = 36$ Nm
Screw $d = 12,0$ mm:	$M_{y,k} = 50$ Nm

Stainless (1.4301 or 1.4567) steel

Screw $d = 4,2$ mm:	$M_{y,k} = 1,3$ Nm
Screw $d = 4,5$ mm:	$M_{y,k} = 2,7$ Nm
Screw $d = 4,8$ mm:	$M_{y,k} = 5,0$ Nm
Screw $d = 5,0$ mm:	$M_{y,k} = 4,7$ Nm
Screw $d = 6,5$ mm:	$M_{y,k} = 12$ Nm

Where

$d$  outer thread diameter [mm]

The embedding strength for screws in non-pre-drilled holes arranged at an angle between screw axis and grain direction,  $30^\circ \leq \alpha \leq 90^\circ$  is:

$$f_{h,k} = \frac{0,082 \cdot \rho_k \cdot d^{-0,3}}{2,5 \cdot \cos^2 \alpha + \sin^2 \alpha} \quad [\text{N/mm}^2]$$

and accordingly for screws in pre-drilled holes:

$$f_{h,k} = \frac{0,082 \cdot \rho_k \cdot (1 - 0,01 \cdot d)}{2,5 \cdot \cos^2 \alpha + \sin^2 \alpha} \quad [\text{N/mm}^2]$$

Where

$\rho_k$  characteristic timber density [kg/m<sup>3</sup>];

$d$  outer thread diameter [mm];

$\alpha$  angle between screw axis and grain direction.

The embedding strength for screws arranged parallel to the plane of cross laminated timber, independent of the angle between screw axis and grain direction,  $0^\circ \leq \alpha \leq 90^\circ$ , shall be calculated from:

$$f_{h,k} = 20 \cdot d^{-0,5} \quad [\text{N/mm}^2]$$

Where

d outer thread diameter [mm]

The embedding strength for screws in the wide face of cross laminated timber should be assumed as for solid timber based on the characteristic density of the outer layer. If relevant, the angle between force, screw axis and grain direction of the outer layer should be taken into account.

The direction of the lateral force shall be perpendicular to the screw axis and parallel to the wide face of the cross laminated timber.

### Bending angle

A minimum plastic bending angle of  $45^\circ/d^{0,7} + 20^\circ$  was reached without breaking the screws.

### Axial withdrawal capacity

The characteristic axial withdrawal capacity of NOVA screws in solid timber (softwood), glued laminated timber, cross-laminated timber or laminated veneer lumber members at an angle of  $30^\circ \leq \alpha \leq 90^\circ$  to the grain shall be calculated according to EN 1995-1-1:2008 from:

$$F_{ax,\alpha,Rk} = \frac{n_{ef} \cdot f_{ax,k} \cdot d \cdot \ell_{ef}}{1,2 \cdot \cos^2 \alpha + \sin^2 \alpha} \cdot \left( \frac{\rho_k}{350} \right)^{0,8} \quad [\text{N}]$$

Where

$F_{ax,\alpha,Rk}$  characteristic withdrawal capacity of the screw at an angle  $\alpha$  to the grain [N]

$n_{ef}$  effective number of screws according to EN 1995-1-1:2008

$f_{ax,k}$  Characteristic withdrawal parameter  
Screws without drill tip (pages 10 to 19):

Screw  $3,5 \text{ mm} \leq d < 6,0 \text{ mm}$ :

$$f_{ax,k} = 13,0 \text{ N/mm}^2$$

Screw  $6,0 \text{ mm} \leq d \leq 10,0 \text{ mm}$ :

$$f_{ax,k} = 11,0 \text{ N/mm}^2$$

Screw  $d \geq 10,0 \text{ mm}$ :  $f_{ax,k} = 10,0 \text{ N/mm}^2$

Screws with drill tip (pages 20 to 25):

Screw  $4,2 \text{ mm} \leq d < 4,5 \text{ mm}$ :

$$f_{ax,k} = 11,0 \text{ N/mm}^2$$

Screw  $d = 4,8 \text{ mm}$ :  $f_{ax,k} = 8,0 \text{ N/mm}^2$

Screw  $d = 5,0 \text{ mm}$ :  $f_{ax,k} = 10,0 \text{ N/mm}^2$

Screw  $d = 6,5 \text{ mm}$ :  $f_{ax,k} = 13,0 \text{ N/mm}^2$

d outer thread diameter [mm]

$\ell_{ef}$  Penetration length of the threaded part according to EN 1995-1-1:2008 [mm]  
For screws with drill tip (see pages 20 to 25), the length of the drill tip must not be considered

$\alpha$  Angle between grain and screw axis ( $\alpha \geq 30^\circ$ )

$\rho_k$  Characteristic density [ $\text{kg/m}^3$ ]

For screws penetrating more than one layer of cross laminated timber, the different layers may be taken into account proportionally.

The axial withdrawal capacity for screws arranged parallel to the plane of laminated veneer lumber and at an angle of  $30^\circ \leq \alpha \leq 90^\circ$  to the grain shall be reduced by 20 %.

The axial withdrawal capacity is limited by the head pull-through capacity and the tensile capacity of the screw.

The axial slip modulus  $K_{ser}$  of the threaded part of a screw for the serviceability limit state should be taken independent of angle  $\alpha$  to the grain as:

$$K_{ser} = 25 \cdot d \cdot \ell_{ef} \quad [\text{N/mm}],$$

Where

d outer thread diameter [mm]

$\ell_{ef}$  penetration length in the timber member [mm]

### Head pull-through capacity

The characteristic head pull-through capacity of NOVA screws shall be calculated according to EN 1995-1-1:2008 from:

$$F_{ax,\alpha,Rk} = n_{ef} \cdot f_{head,k} \cdot d_h^2 \cdot \left( \frac{\rho_k}{350} \right)^{0,8} \quad [\text{N}]$$

where:

$F_{ax,\alpha,Rk}$  characteristic head pull-through capacity of the connection at an angle  $\alpha \geq 30^\circ$  to the grain [N]

$n_{ef}$  effective number of screws according to EN 1995-1-1:2008

$f_{head,k}$  characteristic head pull-through parameter [ $\text{N/mm}^2$ ]

$d_h$  Diameter of the screw head or the washer [mm]. Outer diameter of washers  $d_k > 32 \text{ mm}$  shall not be considered.

$\rho_k$  characteristic density [ $\text{kg/m}^3$ ], for wood-based panels  $\rho_k = 380 \text{ kg/m}^3$

Characteristic head pull-through parameter for screws in connections with timber and in connections with wood-based panels with thicknesses above 20 mm:

Screws  $3,5 \text{ mm} \leq d < 6,0 \text{ mm}$ :  $f_{\text{head,k}} = 20,0 \text{ N/mm}^2$   
 Screws  $6,0 \text{ mm} \leq d \leq 8,0 \text{ mm}$ :  $f_{\text{head,k}} = 14,0 \text{ N/mm}^2$   
 Screws  $d \geq 10,0 \text{ mm}$ :  $f_{\text{head,k}} = 9,4 \text{ N/mm}^2$

Characteristic head pull-through parameter for screws in connections with wood-based panels with thicknesses between 12 mm and 20 mm:

$$f_{\text{head,k}} = 8 \text{ N/mm}^2$$

Screws in connections with wood-based panels with a thickness below 12 mm (minimum thickness of the wood based panels of  $1,2 \cdot d$  with  $d$  as outer thread diameter):

$$f_{\text{head,k}} = 8 \text{ N/mm}^2$$

limited to  $F_{\text{ax,Rk}} = 400 \text{ N}$

The head diameter  $d_h$  shall be greater than  $1,8 \cdot d_s$ , where  $d_s$  is the smooth shank or the wire diameter. Otherwise the characteristic head pull-through capacity  $F_{\text{ax},\alpha,\text{Rk}} = 0$ .

The minimum thickness of wood-based panels according to the clause II.1 must be observed.

In steel-to-timber connections the head pull-through capacity is not governing.

### Tensile capacity

The characteristic tensile strength  $f_{\text{tens,k}}$  of NOVA screws is:

carbon or stainless (1.4006) steel

$d = 3,5 \text{ mm}$ :	3,8 kN
$d = 4,0 \text{ mm}$ :	5,0 kN
$d = 4,2 \text{ mm}$ :	5,5 kN
$d = 4,5 \text{ mm}$ :	6,4 kN
$d = 4,8 \text{ mm}$ :	7,2 kN
$d = 5,0 \text{ mm}$ :	7,9 kN
$d = 6,0 \text{ mm}$ :	11 kN
$d = 6,5 \text{ mm}$ :	15 kN
$d = 8,0 \text{ mm}$ :	20 kN
$d = 8,5 \text{ mm}$ :	30 kN
$d = 10,0 \text{ mm}$ :	32 kN
$d = 12,0 \text{ mm}$ :	38 kN

stainless (1.4301 or 1.4567) steel

$d = 4,2 \text{ mm}$ :	3,4 kN
$d = 4,5 \text{ mm}$ :	4,8 kN
$d = 4,8 \text{ mm}$ :	6,5 kN
$d = 5,0 \text{ mm}$ :	5,7 kN
$d = 6,5 \text{ mm}$ :	12 kN

For screws used in combination with steel plates, the tear-off capacity of the screw head including a washer shall be greater than the tensile capacity of the screw.

### Combined laterally and axially loaded screws

For screwed connections subjected to a combination of axial and lateral load, the following expression should be satisfied:

$$\left( \frac{F_{\text{ax,Ed}}}{F_{\text{ax,Rd}}} \right)^2 + \left( \frac{F_{\text{v,Ed}}}{F_{\text{v,Rd}}} \right)^2 \leq 1$$

where

$F_{\text{ax,Ed}}$	axial design load of the screw
$F_{\text{v,Ed}}$	lateral design load of the screw
$F_{\text{ax,Rd}}$	design load-carrying capacity of an axially loaded screw
$F_{\text{v,Rd}}$	design load-carrying capacity of a laterally loaded screw

### 3.5 Aspects related to the performance of the product

#### 3.5.1 Corrosion protection in service class 1, 2 and 3.

The NOVA screws are produced from carbon wire. They are brass-plated, nickel-plated bronze finished or electrogalvanised and e.g. yellow or blue chromated with thicknesses of the zinc coating from 4 – 16  $\mu\text{m}$  or have a zinc flake coating with thicknesses from 10 – 20  $\mu\text{m}$ .

Steel no. 1.4006, 1.4301 or 1.4567 is used for screws made from stainless steel.

### 3.6 General aspects related to the intended use of the product

The screws are manufactured in accordance with the provisions of the European Technical Assessment using the automated manufacturing process as identified during the inspection of the plant by the assessment body issuing the ETA and the notified body and laid down in the technical documentation.

The screws are used for connections in load bearing timber structures between members of solid timber (softwood), glued laminated timber, cross-laminated timber (minimum diameter  $d = 6,0 \text{ mm}$ ), and laminated veneer lumber, similar glued members, wood-based panels or steel members.

The screws may be used for connections in load bearing timber structures with structural members according to an associated European Technical Assessment, if according to the associated European Technical Assessment of the structural member a connection in load bearing timber structures with screws according to a European Technical Assessment is allowed.

NOVA screws with diameters of at least 6 mm may also be used for the fixing of thermal insulation material on top of rafters.

A minimum of two screws should in general be used for connections in load bearing timber structures.

The minimum penetration depth in structural members made of solid, glued or cross-laminated timber is  $4 \cdot d$ .

Wood-based panels and steel plates should only be arranged on the side of the screw head. The minimum thickness of wood-based panels should be  $1,2 \cdot d$ . Furthermore the minimum thickness for following wood-based panels should be:

- Plywood, Fibreboards: 6 mm
- Particleboards, OSB, Cement Particleboards: 8 mm
- Solid wood panels: 12 mm

For structural members according to ETA's the terms of the ETA must be considered.

If screws with an outer thread diameter  $d \geq 8$  mm are used in load bearing timber structures, the structural solid or glued laminated timber, laminated veneer lumber and similar glued members must be from spruce, pine or fir. This does not apply for screws in pre-drilled holes.

The minimum angle between the screw axis and the grain direction is  $\alpha = 30^\circ$ .

The screws shall be driven into the wood with or without pre-drilling. The maximum pre-drilling diameters are the inner thread diameter for the length of the threaded part and the smooth shank diameter for the depth of the smooth shank. The hole diameter in steel members must be predrilled with a suitable diameter.

Only the equipment prescribed by NOVA Co. Ltd. shall be used for driving the screws.

In connections with screws with countersunk head according to Annex A the head must be flush with the surface of the connected structural member. A deeper countersink is not allowed.

For structural timber members, minimum spacing and distances for screws in predrilled holes are given in EN 1995-1-1:2010 (Eurocode 5) clause 8.3.1.2 and table 8.2 as for nails in predrilled holes. Here, the outer thread diameter  $d$  must be considered.

For NOVA screws in non-predrilled holes, minimum spacing and distances are given in EN 1995-1-1:2004 (Eurocode 5) clause 8.3.1.2 and table 8.2 as for nails in non-predrilled holes. Here, the outer thread diameter  $d$  must be considered.

For Douglas fir members minimum spacing and distances parallel to the grain shall be increased by 50%.

Minimum distances from loaded or unloaded ends must be  $15 \cdot d$  for screws in non-predrilled holes with outer thread diameter  $d \geq 8$  mm and timber thickness  $t < 5 \cdot d$ .

Minimum distances from the unloaded edge perpendicular to the grain may be reduced to  $3 \cdot d$  also for timber thickness  $t < 5 \cdot d$ , if the spacing parallel to the grain and the end distance is at least  $25 \cdot d$ .

Minimum distances and spacing for screws in the plane surface of cross laminated timber members with a minimum thickness  $t = 10 \cdot d$  may be taken as (see Annex B):

Spacing $a_1$ parallel to the grain	$a_1 = 4 \cdot d$
Spacing $a_2$ perpendicular to the grain	$a_2 = 2,5 \cdot d$
Distance $a_{3,c}$ from centre of the screw-part in timber to the unloaded end grain	$a_{3,c} = 6 \cdot d$
Distance $a_{3,t}$ from centre of the screw-part in timber to the loaded end grain	$a_{3,t} = 6 \cdot d$
Distance $a_{4,c}$ from centre of the screw-part in timber to the unloaded edge	$a_{4,c} = 2,5 \cdot d$
Distance $a_{4,t}$ from centre of the screw-part in timber to the loaded edge	$a_{4,t} = 6 \cdot d$

Minimum distances and spacing for screws in the edge surface of cross laminated timber members with a minimum thickness  $t = 10 \cdot d$  and a minimum penetration depth perpendicular to the edge surface may be taken as (see Annex B):

Spacing $a_1$ parallel to the CLT plane	$a_1 = 10 \cdot d$
Spacing $a_2$ perpendicular to the CLT plane	$a_2 = 4 \cdot d$
Distance $a_{3,c}$ from centre of the screw-part in timber to the unloaded end	$a_{3,c} = 7 \cdot d$
Distance $a_{3,t}$ from centre of the screw-part in timber to the loaded end	$a_{3,t} = 12 \cdot d$
Distance $a_{4,c}$ from centre of the screw-part in timber to the unloaded edge	$a_{4,c} = 3 \cdot d$
Distance $a_{4,t}$ from centre of the screw-part in timber to the loaded edge	$a_{4,t} = 6 \cdot d$

Minimum distances and spacing for NOVA screws in cross laminated timber are given in Annex B.

Minimum thickness for structural members is  $t = 24$  mm for screws with outer thread diameter  $d < 8$  mm,  $t = 30$  mm for screws with outer thread diameter  $d = 8$  mm, and  $t = 40$  mm for screws with outer thread diameter  $d = 10$  mm.



#### **4 Assessment and verification of constancy of performance (hereinafter AVCP) system applied, with reference to its legal base**

##### **4.1 AVCP system**

According to the decision 97/176/EC of the European Commission<sup>1</sup>, as amended, the system(s) of assessment and verification of constancy of performance (see Annex V to Regulation (EU) No 305/2011) is **3**.

#### **5 Technical details necessary for the implementation of the AVCP system, as provided for in the applicable EAD**

Technical details necessary for the implementation of the AVCP system are laid down in the control plan deposited at ETA-Danmark prior to CE marking

Issued in Copenhagen on 2025-03-03 by



Thomas Bruun  
Managing Director, ETA-Danmark

**Annex A**  
**Drawings of Nova Fastener screws**

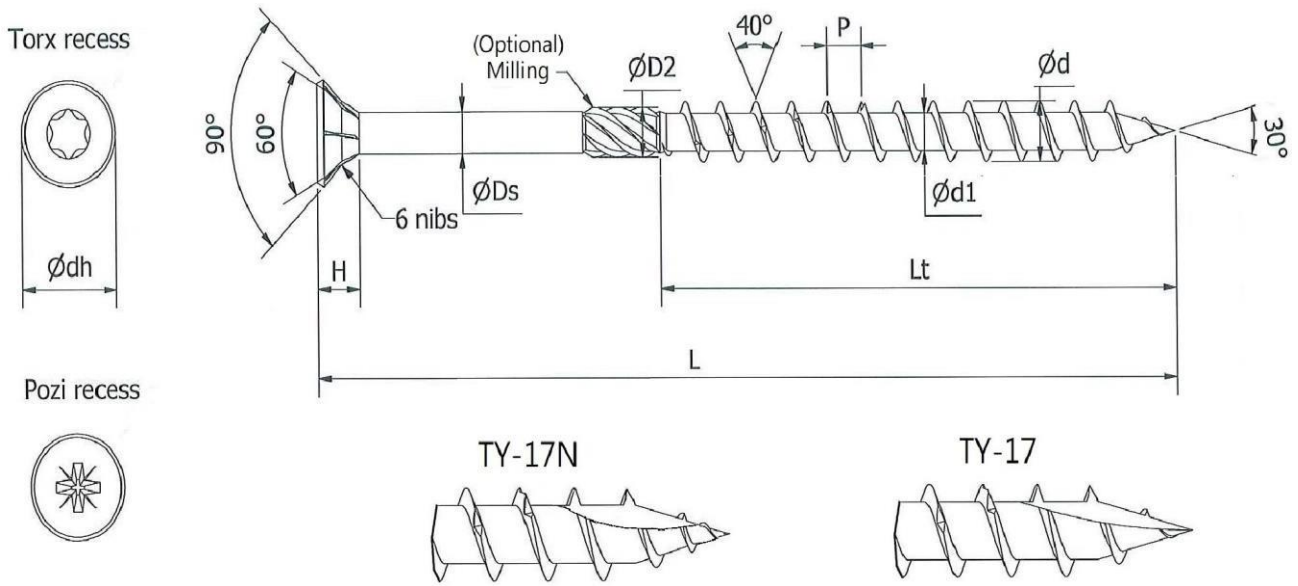

Unit: mm

Material: Carbon Steel or Stainless Steel (information kept at ETA-Denmark)

SIZE	M3.5	M4	M4.5	M5	M6	M8	M10	M12	
$\varnothing dh$	6.50	7.50	8.50	9.50	11.50	14.00	18.00	19.00	
	7.00	8.00	9.00	10.00	12.00	15.00	19.00	21.00	
H	3.30 Ref	3.70 Ref	4.10 Ref	4.50 Ref	5.70 Ref	7.00 Ref	8.00 Ref	9.70 Ref	
$\varnothing D2$	2.60	2.80	3.30	3.80	4.50	6.50	8.30	9.50	
	2.90	3.20	3.60	4.10	5.50	7.10	8.80	9.80	
$\varnothing d$	3.30	3.80	4.30	4.70	5.75	7.60	9.70	11.30	
	3.60	4.10	4.60	5.15	6.15	8.20	10.30	12.00	
$\varnothing d1$	2.00	2.20	2.55	3.00	3.80	5.10	6.00	6.90	
	2.30	2.80	2.90	3.45	4.20	5.50	6.50	7.40	
P	2.02	2.27	2.52	2.79	4.41	5.04	5.94	5.94	
	2.46	2.77	3.08	3.41	5.39	6.16	7.26	7.26	
$\varnothing Ds$	2.40	2.60	2.80	3.50	4.20	5.70	6.90	7.80	
	2.60	2.80	3.20	3.70	4.45	5.90	7.20	8.00	
Lt	min	14.00	16.00	18.00	20.00	24.00	32.00	40.00	48.00
	max	30.00	50.00	50.00	70.00	70.00	80.00	90.00	120.00
L	min	18.00	20.00	22.00	24.00	30.00	40.00	50.00	60.00
	max	50.00	80.00	80.00	160.00	300.00	400.00	400.00	400.00

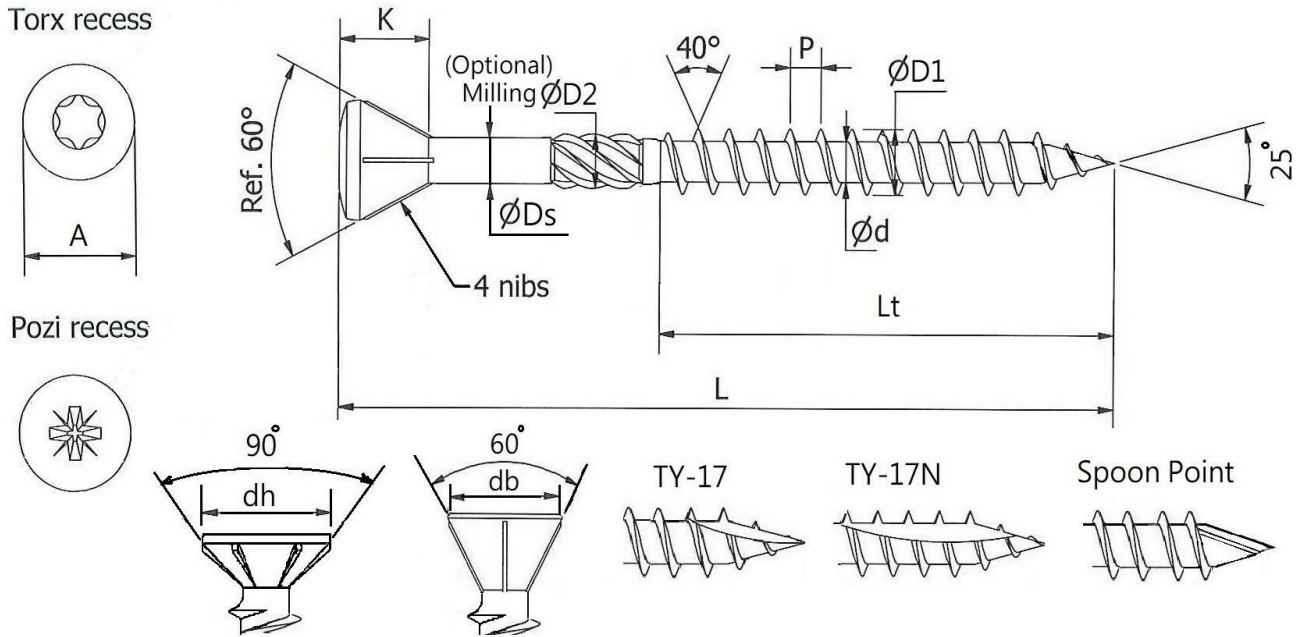

Unit: mm

Material: Carbon Steel or Stainless Steel (information kept at ETA-Denmark)

SIZE	M4	M4.5	M5	
A	5.80	6.80	7.30	
	6.20	7.20	7.70	
K	3.40	4.20	4.65	
	3.70	4.40	4.95	
dh	7.50	8.50	9.50	
	8.00	9.00	10.00	
db	5.80	6.80	7.30	
	6.20	7.20	7.70	
ØD2	3.30	3.80	4.28	
	3.68	4.20	4.73	
ØD1	3.90	4.40	4.90	
	4.10	4.60	5.10	
Ød	2.30	2.50	2.90	
	2.50	2.70	3.10	
P	1.62	1.80	1.98	
	1.98	2.20	2.42	
ØDs	2.60	3.00	3.50	
	2.80	3.20	3.70	
Lt	min	16.00	18.00	20.00
	max	36.00	48.00	60.00
L	min	30.00	30.00	30.00
	max	60.00	80.00	100.00

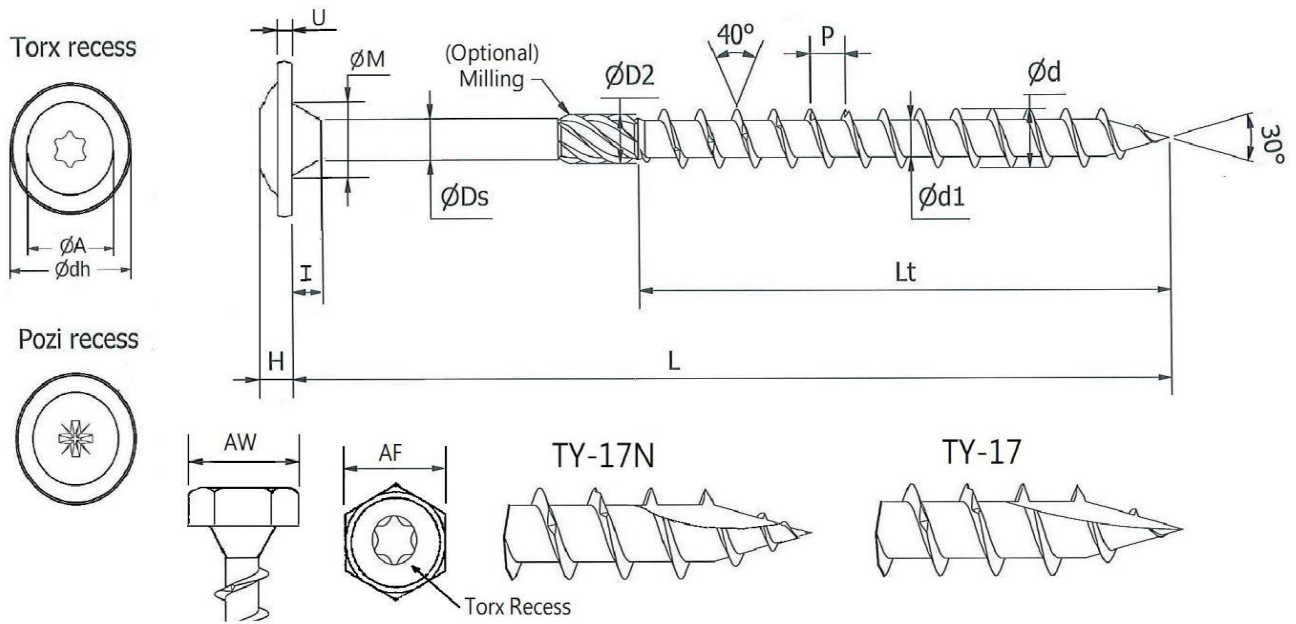

Unit: mm

Material: Carbon Steel or Stainless Steel (information kept at ETA-Denmark)

SIZE	M6	M8	M10	
ØA	10.00	14.50	18.50	
	11.00	18.00	22.00	
Ødh	13.00	20.00	23.00	
	15.00	24.00	27.00	
U	0.70	1.50	1.70	
	1.30	2.10	2.30	
I	2.70	3.20	3.60	
	3.40	4.00	4.40	
AW	8.70	11.00	14.30	
AF	8.00	10.00	13.00	
ØM	6.00	9.00	11.00	
	8.00	11.00	12.00	
ØDs	4.20	5.60	6.90	
	4.40	6.00	7.10	
P	4.41	4.68	5.94	
	5.39	6.05	7.26	
Ød	5.75	7.80	9.80	
	6.15	8.10	10.20	
Ød1	3.80	5.20	6.10	
	4.15	5.50	6.40	
ØD2	4.50	6.70	8.00	
	5.10	7.20	8.80	
Lt	min	24.00	32.00	40.00
	max	70.00	80.00	90.00
L	min	25.00	33.00	41.00
	max	300.00	400.00	400.00

Torx Recess

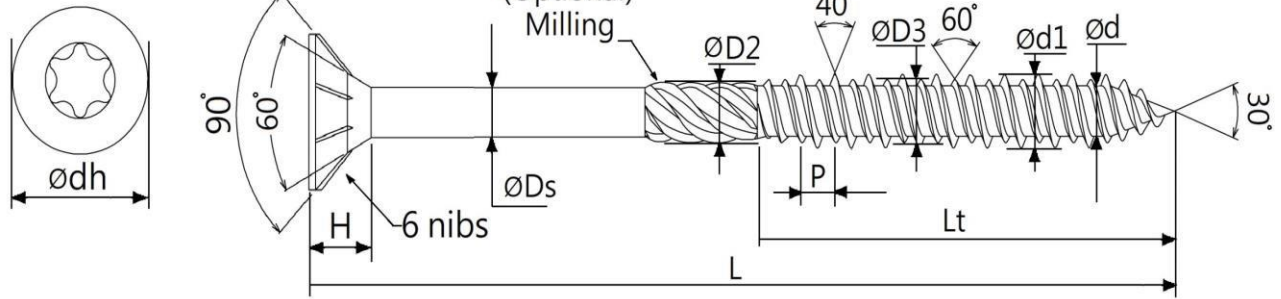

Pozi Recess

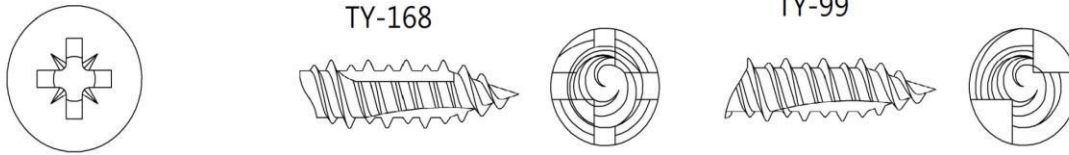

Unit: mm

Material: Carbon Steel or Stainless Steel (information kept at ETA-Denmark)

SIZE	M3.5	M4	M4.5	M5	M6	M8	M10	M12	
$\varnothing dh$	6.50	7.50	8.50	9.50	11.50	14.00	18.00	20.00	
	7.00	8.00	9.00	10.00	12.00	15.00	19.00	21.00	
H	3.30 Ref	3.70 Ref	4.10 Ref	4.50 Ref	5.70 Ref	7.00 Ref	8.00 Ref	9.70 Ref	
$\varnothing D2$	2.85	3.30	3.80	4.28	4.50	6.50	8.00	8.36	
	3.15	3.68	4.20	4.73	5.00	6.80	8.50	9.24	
$\varnothing d$	3.30	3.80	4.30	4.70	5.75	7.80	9.80	11.50	
	3.50	4.00	4.50	5.15	6.15	8.10	10.20	12.00	
$\varnothing D3$	2.60	3.00	3.30	3.85	4.70	6.40	7.80	8.70	
	2.80	3.20	3.50	4.15	5.00	6.70	8.20	9.20	
$\varnothing d1$	2.00	2.20	2.55	3.00	3.70	5.10	6.00	6.50	
	2.25	2.45	2.80	3.45	4.15	5.50	6.40	6.95	
P	2.25	2.52	2.70	2.79	4.41	5.04	5.94	7.20	
	2.75	3.08	3.30	3.41	5.39	6.16	7.26	8.80	
$\varnothing Ds$	2.40	2.60	3.00	3.50	4.20	5.70	6.90	7.80	
	2.60	2.80	3.20	3.70	4.40	5.90	7.20	8.00	
Lt	min	14.00	16.00	18.00	20.00	24.00	32.00	48.00	
	max	30.00	50.00	50.00	70.00	70.00	80.00	90.00	120.00
L	min	18.00	20.00	22.00	24.00	30.00	40.00	50.00	60.00
	max	50.00	80.00	80.00	160.00	300.00	400.00	400.00	400.00

Torx Recess

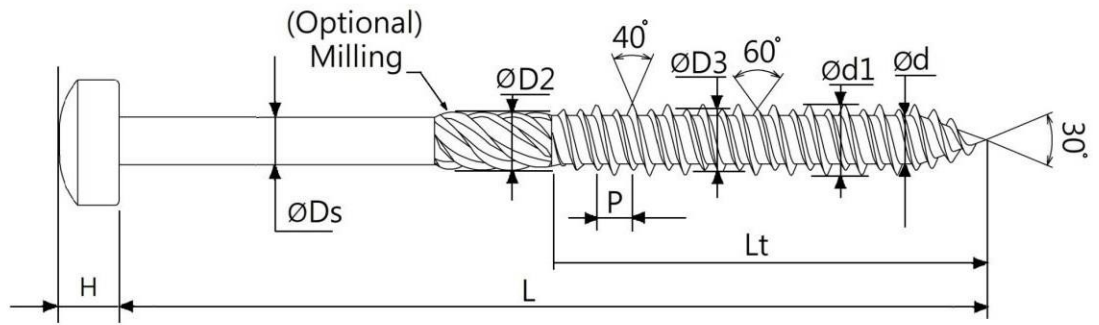
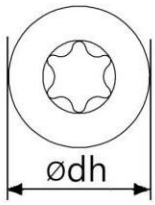

Pozi Recess

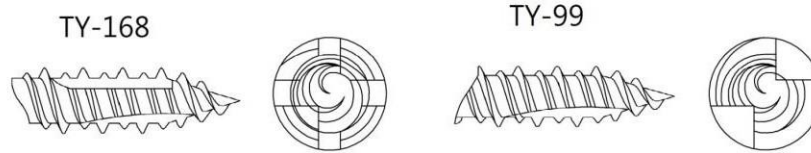
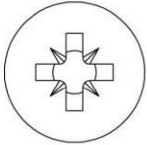

Unit: mm

Material: Carbon Steel or Stainless Steel (information kept at ETA-Denmark)

SIZE	M3.5	M4	M4.5	M5	M6
Ødh	6.64	7.64	8.65	9.64	11.57
	7.00	8.00	9.00	10.00	12.00
H	2.58	2.95	3.35	3.65	4.45
	2.82	3.25	3.65	3.95	4.75
ØD2	2.85	3.30	3.80	4.53	4.50
	3.15	3.68	4.20	4.73	5.00
Ød	3.30	3.80	4.30	4.70	5.75
	3.50	4.00	4.50	5.15	6.15
ØD3	2.60	3.00	3.30	3.85	4.70
	2.80	3.20	3.50	4.15	5.00
Ød1	2.00	2.20	2.55	3.00	3.70
	2.25	2.45	2.85	3.45	4.15
P	2.25	2.52	2.70	2.79	4.41
	2.75	3.08	3.30	3.41	5.39
ØDs	2.40	2.60	3.00	3.50	4.20
	2.60	2.80	3.20	3.70	4.40
Lt	min	14.00	16.00	18.00	24.00
	max	30.00	50.00	50.00	70.00
L	min	15.00	17.00	19.00	25.00
	max	50.00	80.00	80.00	300.00

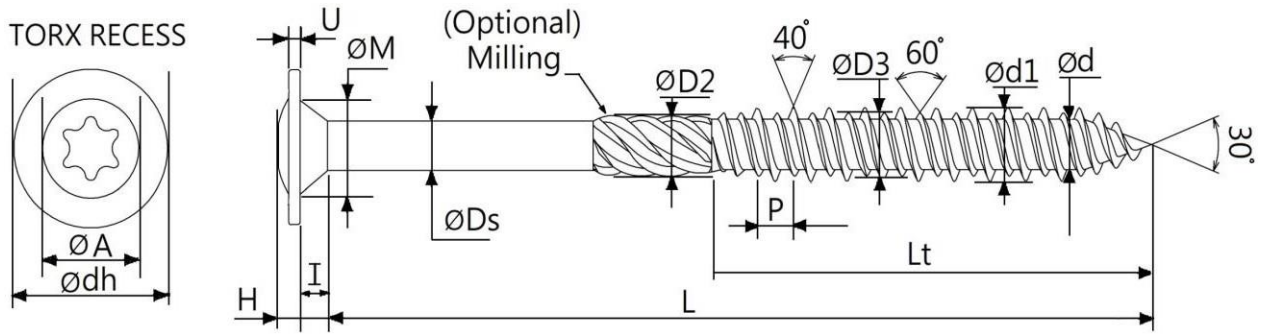

POZI RECESS

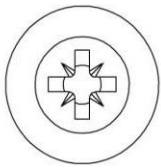

TY-168

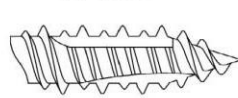

TY-99

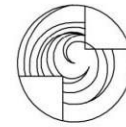
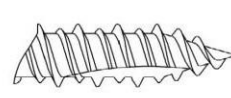

Unit: mm

Material: Carbon Steel (information kept at ETA-Denmark)

SIZE	M6	M8	M10	
ØA	10.00	14.50	18.50	
	11.00	16.00	22.00	
Ødh	13.50	20.50	23.50	
	14.50	23.50	26.50	
U	0.70	1.50	1.70	
	1.30	2.10	2.30	
I	2.70	3.20	3.60	
	3.40	4.00	4.40	
ØM	6.00	9.00	11.00	
	8.00	11.00	12.00	
ØDs	4.20	5.60	6.90	
	4.40	6.00	7.10	
P	4.41	5.04	5.94	
	5.39	6.16	7.26	
Ød	5.75	7.80	9.80	
	6.15	8.10	10.20	
ØD3	4.70	6.40	7.80	
	5.00	6.70	8.20	
Ød1	3.70	5.10	6.00	
	4.15	5.50	6.40	
Lt	min	24.00	32.00	40.00
	max	70.00	80.00	90.00
L	min	25.00	33.00	41.00
	max	400.00	400.00	400.00

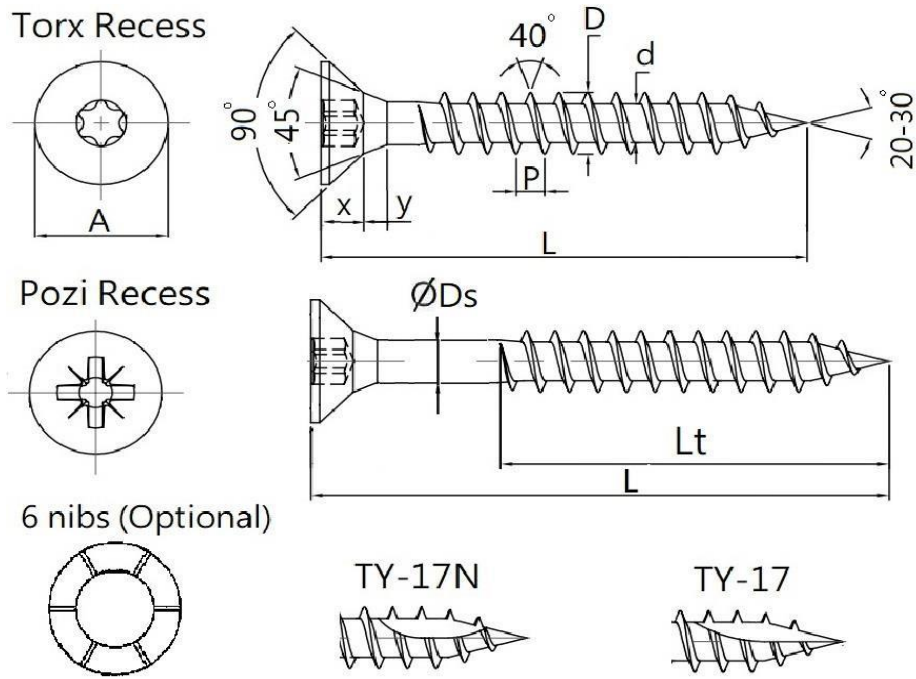

Unit: mm

Material: Carbon Steel or Stainless Steel (information kept at ETA-Denmark)

SIZE	M3.5	M4	M4.5	M5	M6	
A	6.40	7.40	8.40	9.40	11.30	
	7.00	8.00	9.00	10.00	12.00	
D	3.20	3.70	4.20	4.70	5.70	
	3.50	4.00	4.50	5.00	6.00	
d	2.00	2.30	2.50	2.80	3.50	
	2.30	2.60	2.85	3.30	3.80	
ØDs	2.35	2.75	3.10	3.45	4.20	
	2.55	2.95	3.30	3.65	4.40	
X	2.02 Ref	2.12 Ref	2.54 Ref	2.90 Ref	3.39 Ref	
y	1.80 Ref	2.00 Ref	2.20 Ref	2.50 Ref	2.70 Ref	
P	1.40	1.60	1.80	2.00	2.30	
	1.80	2.00	2.20	2.40	2.90	
Lt	min	14.00	16.00	18.00	20.00	24.00
	max	36.00	50.00	68.00	68.00	68.00
L	min	18.00	20.00	22.00	24.00	28.00
	max	60.00	80.00	80.00	120.00	300.00



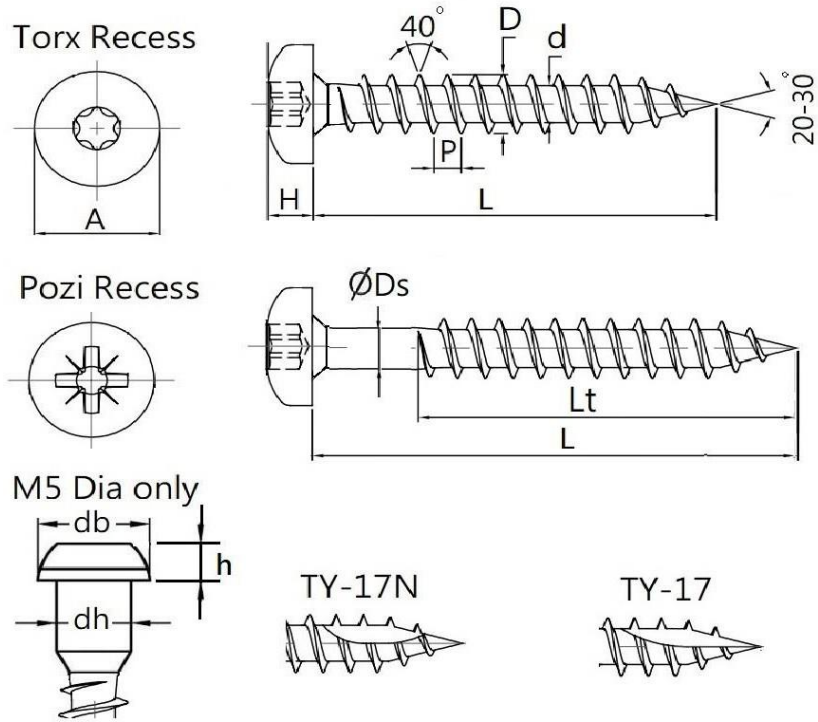

Unit: mm

Material: Carbon Steel or Stainless Steel (information kept at ETA-Denmark)

SIZE	M3.5	M4	M4.5	M5	M6
A	6.60	7.55	8.55	9.55	11.45
	7.00	8.00	9.00	10.00	12.00
H	2.40	2.60	2.90	3.35	3.85
	2.70	2.90	3.20	3.65	4.25
D	3.30	3.75	4.25	4.70	5.70
	3.50	4.00	4.50	5.00	6.00
d	2.00	2.30	2.50	2.80	3.50
	2.20	2.50	2.70	3.00	3.70
dh	--	--	--	4.80	--
	--	--	--		--
db	--	--	--	7.00	--
	--	--	--	7.50	--
h	--	--	--	2.50	--
P	1.35 Ref	1.80 Ref	2.00 Ref	2.20 Ref	2.60 Ref
ØDs	1.60	3.60	4.00	4.40	5.30
	3.65	4.15	4.65	5.20	6.25
Lt	min	14.00	16.00	18.00	20.00
	max	50.00	50.00	68.00	68.00
L	min	15.00	17.00	19.00	21.00
	max	50.00	80.00	80.00	120.00

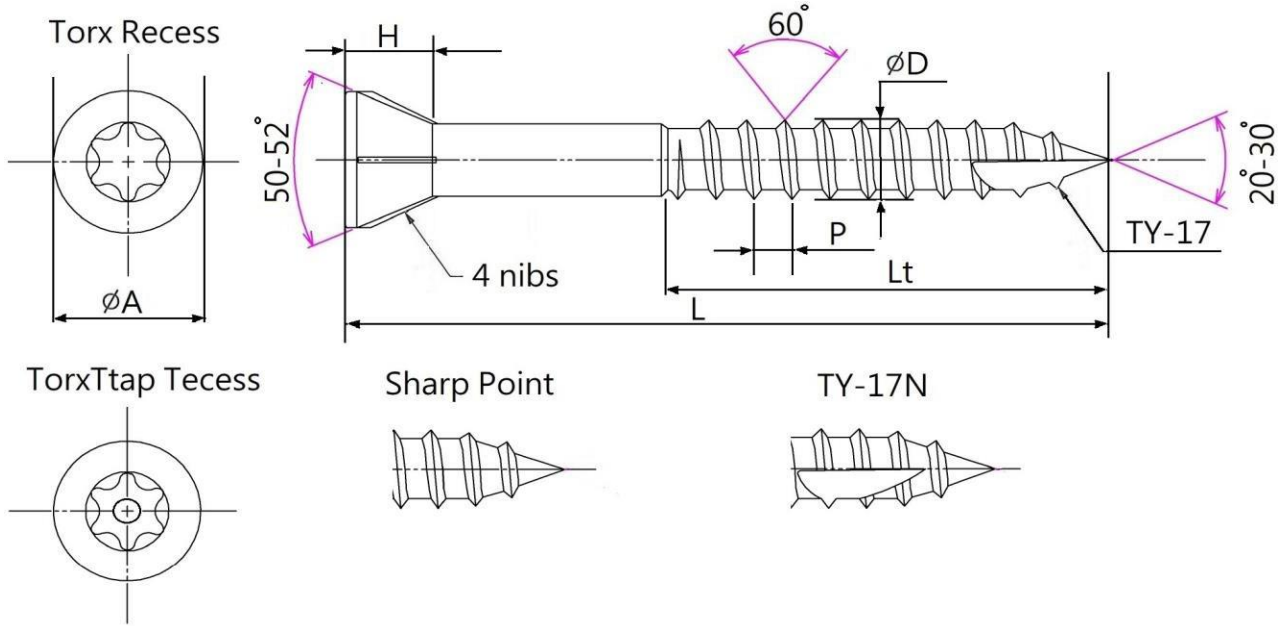

Unit: mm

Material: Carbon Steel or Stainless Steel (information kept at ETA-Denmark)

SIZE	M4.2	M4.8
A	6.80	8.00
	7.30	8.50
H	4.90 Ref	5.80 Ref
øD	4.10	4.70
	4.40	5.00
P	2.52	2.52
	3.08	3.08
Lt	min 32.00	32.00
	max 52.00	54.00
L	min 45.00	45.00
	max 75.00	90.00

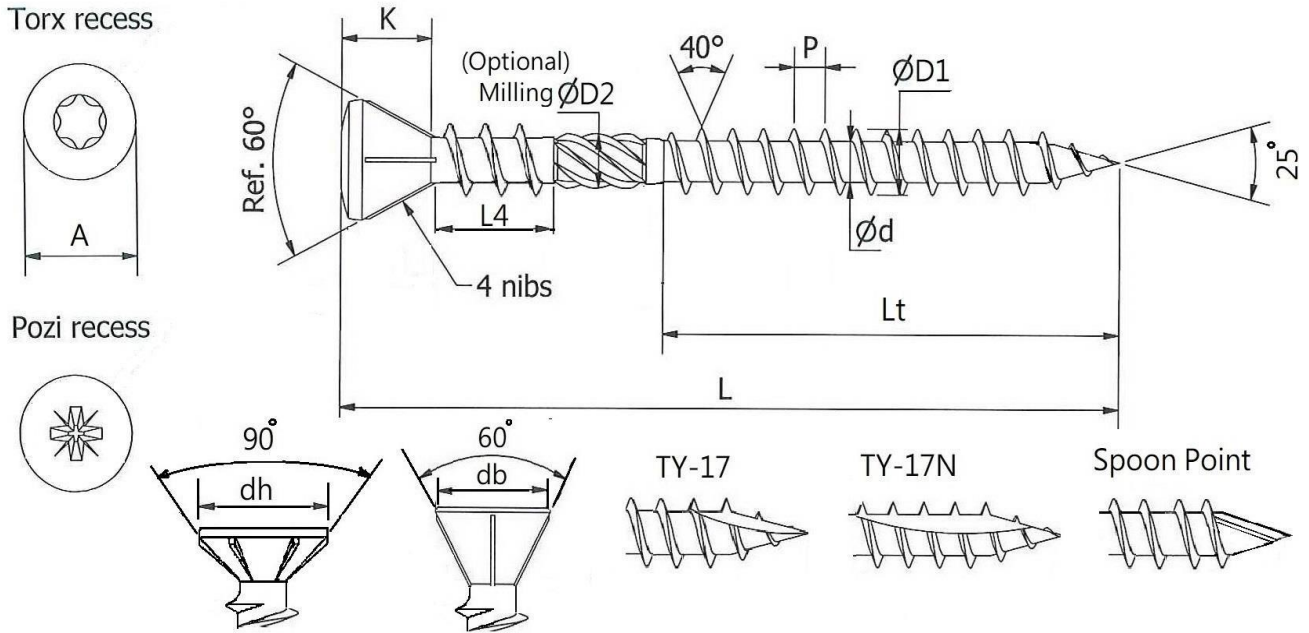

Unit: mm

Material: Carbon Steel or Stainless Steel (information kept at ETA-Denmark)

SIZE	M4	M4.5	M5	
A	5.80	6.80	7.30	
	6.20	7.20	7.70	
K	3.40	4.20	4.65	
	3.70	4.40	4.95	
dh	7.50	8.50	9.50	
	8.00	9.00	10.00	
db	5.80	6.80	7.30	
	6.20	7.20	7.70	
ØD2	3.30	3.80	4.28	
	3.68	4.20	4.73	
ØD1	3.90	4.40	4.90	
	4.10	4.60	5.10	
Ød	2.30	2.50	2.90	
	2.50	2.70	3.10	
P	1.62	1.80	1.98	
	1.98	2.20	2.42	
L4	10.00	10.00	10.00	
Lt	min	16.00	18.00	20.00
	max	36.00	48.00	60.00
L	min	30.00	30.00	30.00
	max	60.00	80.00	100.00

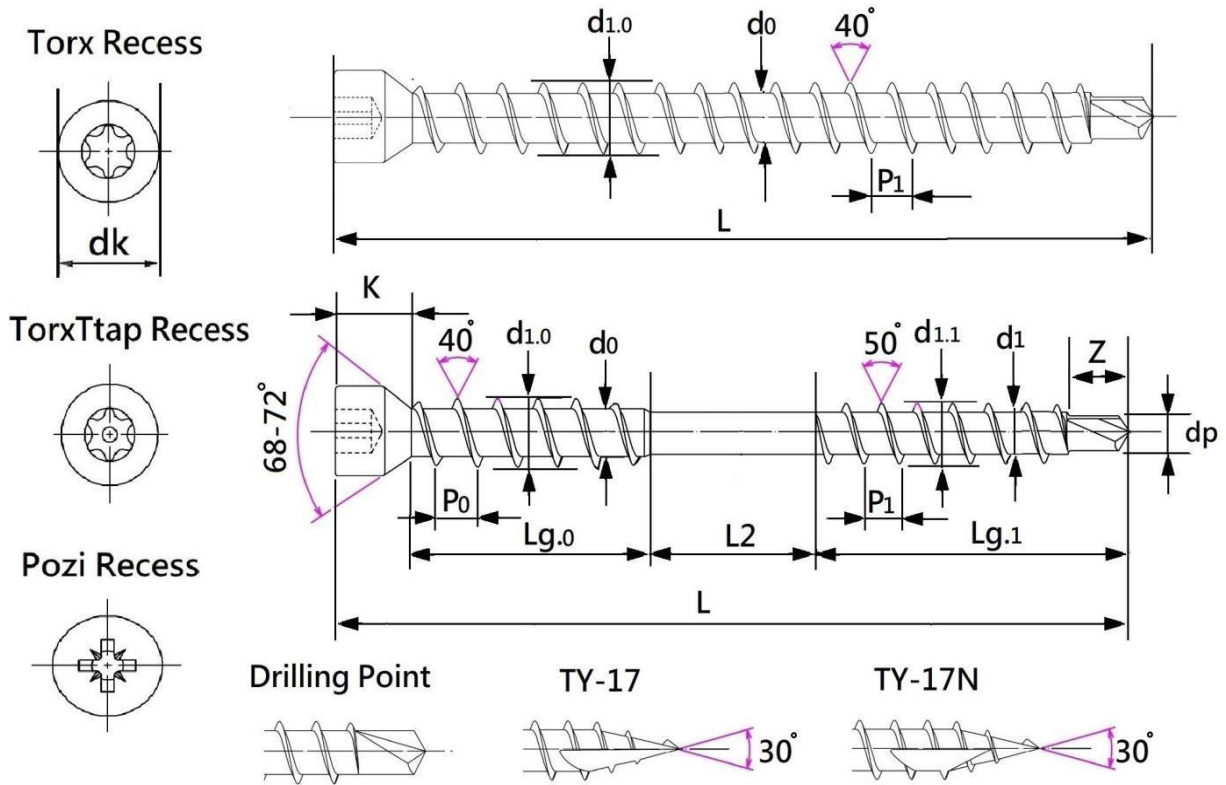

Unit: mm

Material: Carbon Steel (information kept at ETA-Denmark)

SIZE	dk	K	Drive	Po	P1.0	ds
M6.5	7.50-7.90	5.50 Ref	T-30	2.80	3.00	4.50-4.80
	6.50-6.70	4.20 Ref	6.30-6.50	4.10 Ref	5.00 Ref	4.00 Ref
M8.5	dk	K	Drive	Po	P1.0	ds
	9.75-10.25	7.00 Ref	T-40	3.10	3.20	6.30-6.50
	8.70-8.90	5.60 Ref	8.20-8.40	5.70 Ref	5.00 Ref	4.00 Ref

M6.5 DIA: Max Length--200mm\*\*

Min Thread Length: M6.5 size-26mm, M8.5 size-34mm\*

Size	L	Lg.0	L2	Lg.1
80	±1.50	29.0	10.00	*M6.5: 26
				*M8.5: 34
90		34.0		39.0
120		34.0	40.00	39.0
130		34.0	50.00	39.0
140		39.0		44.0
160		59.0	30.00	64.0
180		69.0		74.0
190		74.0		79.0
200**		79.0		84.0
220		89.0		94.0
240		99.0		104.0
260		109.0		114.0
280		119.0		124.0
300	129.0	134.0		

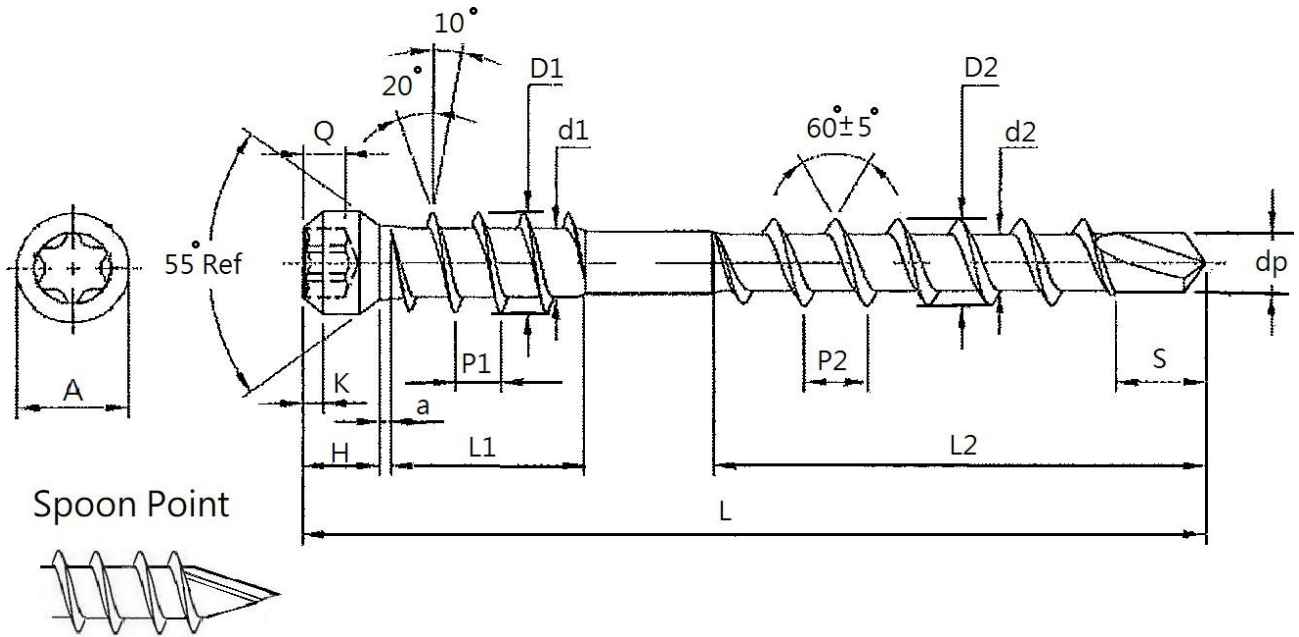

Unit: mm

Material: Carbon Steel or Stainless Steel (information kept at ETA-Denmark)

SIZE	A	H	M	Drive	Q	K	a	D1
M4.2	5.00 Max	4.00 Ref	3.35	T-15	2.00 Min	1.00 Ref	1.35	4.80
	<b>d1</b>	<b>P1</b>	<b>D2</b>	<b>d2</b>	<b>P2</b>	<b>S</b>	<b>dp</b>	<b>L1</b>
	3.05	2.20	4.04	2.55	3.00	4.00	2.75	9.00
	3.35		4.22	2.75		5.00	2.90	

Lt	min	25.00
	max	30.00
L	min	48.00
	max	60.00

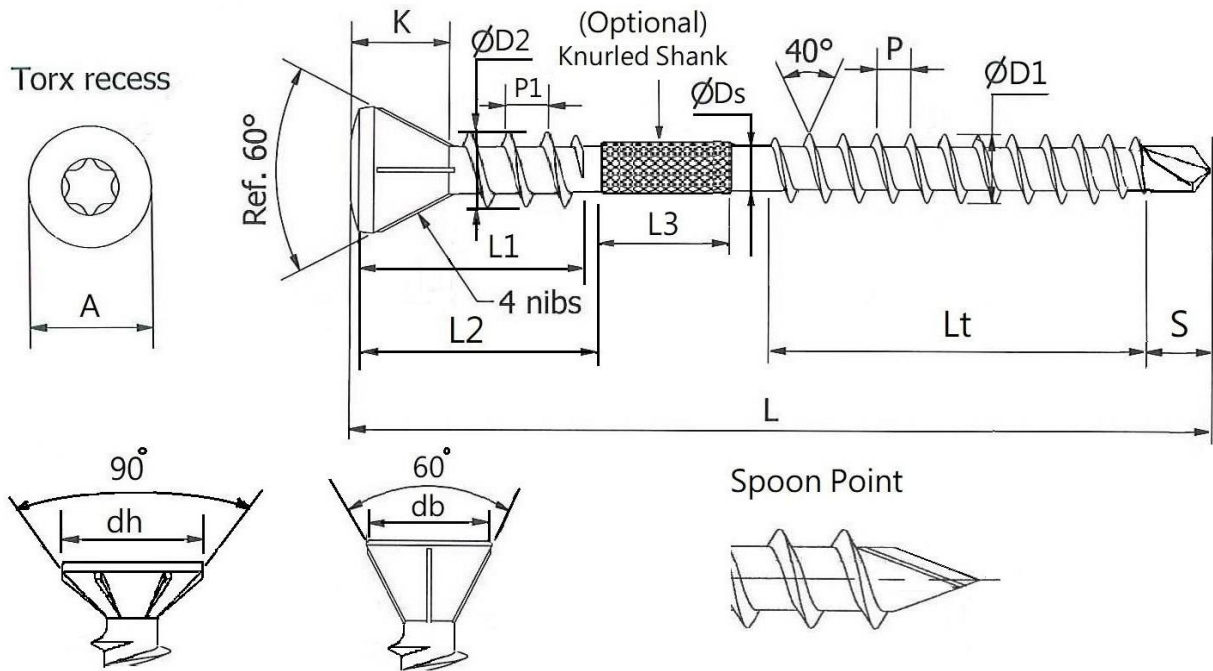

Unit: mm

Material: Carbon Steel (information kept at ETA-Denmark)

SIZE	A	Drive	K	ØD2	P1	Ds	D1
M4.5	6.70	T-20	3.40	4.70	2.00	3.35	4.30
	7.30		4.40	5.00		3.65	4.70
	<b>P</b>	<b>S</b>	<b>dh</b>	<b>db</b>	<b>L1</b>	<b>L2</b>	<b>L3</b>
	2.80	4.00	8.50	6.80	13.0 Max	16.50	10.00
		9.00	7.20				

Lt	min	18.00
	max	24.00
L	min	40.00
	max	80.00

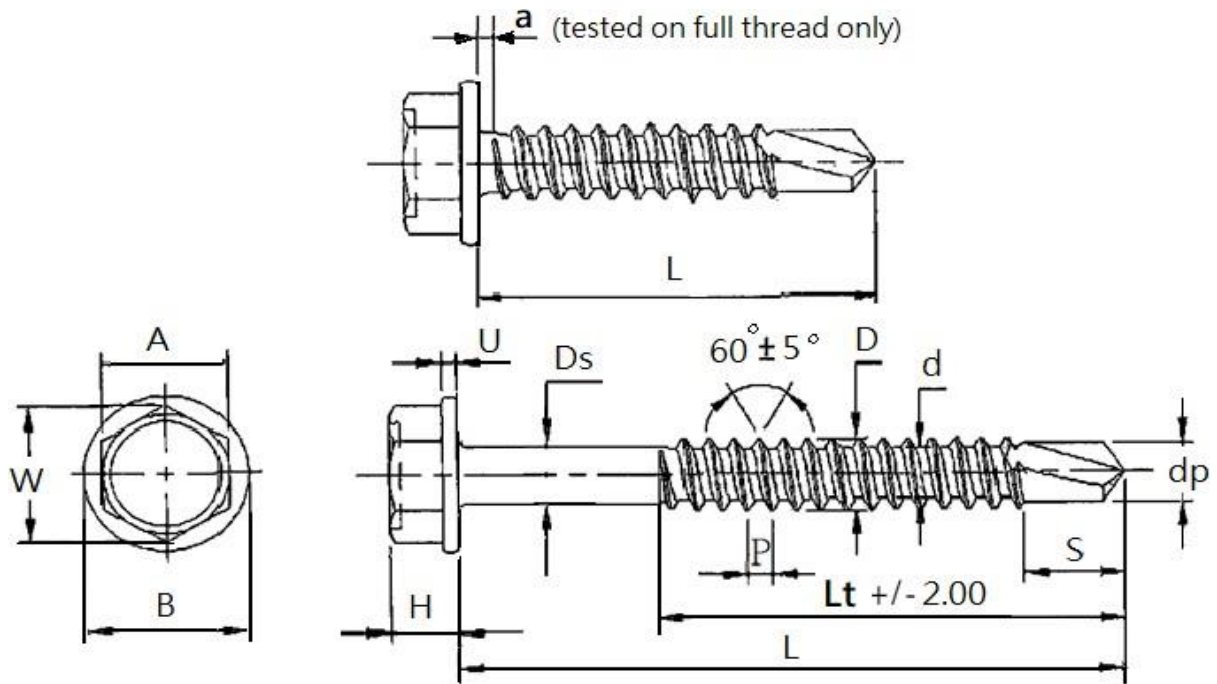

Unit: mm

Material: Stainless Steel (information kept at ETA-Denmark)

SIZE	A	W	B	H	U	D
M4.8	7.78	8.71	9.80	4.15	0.90	4.65
	8.00	Min	10.50	4.45	1.20	4.80
	<b>d</b>	<b>P</b>	<b>S</b>	<b>dp</b>	<b>a</b>	<b>Ds</b>
	3.43	1.60	7.50 Ref	3.85	0.80	3.85
	3.58			4.00	Max	3.95

Lt	min	16.00
	max	100.00
L	min	16.00
	max	100.00

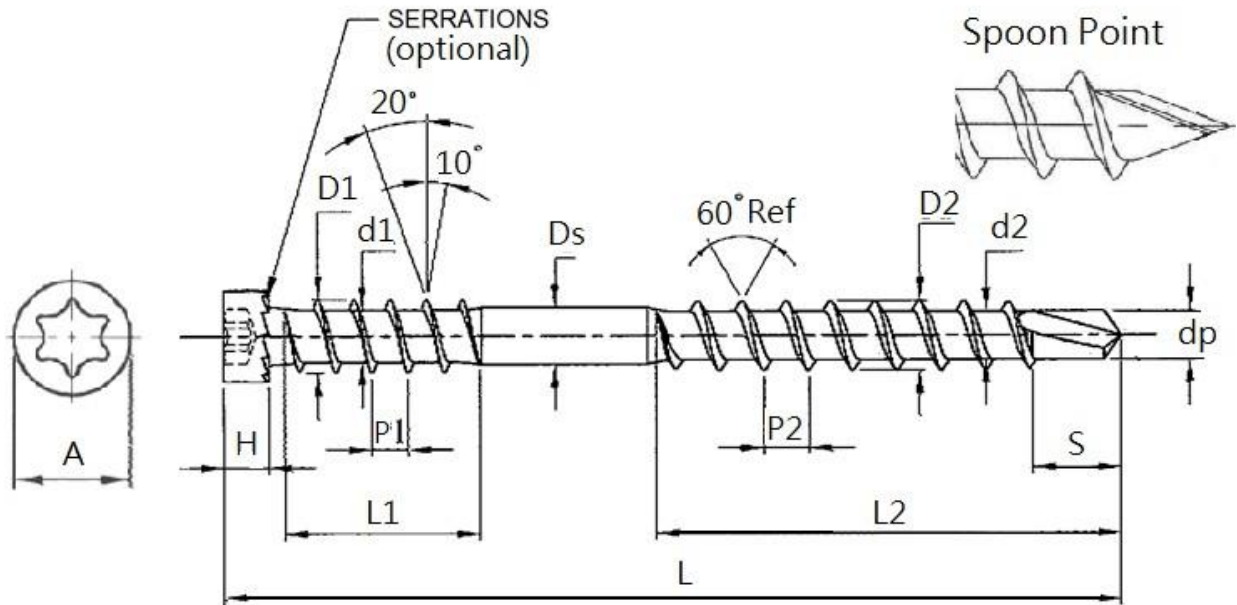

Unit: mm

Material: Stainless Steel (information kept at ETA-Denmark)

SIZE	A	H	D1	d1	D2	d2
M5.0	6.50	2.80	5.20	3.60 Ref	4.80	3.50 Ref
	Max	3.30			5.20	
	<b>P1</b>	<b>P2</b>	<b>Ds</b>	<b>S</b>	<b>dp</b>	<b>L1</b>
	2.6	3.18	3.70 4.10	6.00 Ref	3.35 3.50	10.00

Lt	min	20.00
	max	45.00
L	min	45.00
	max	60.00



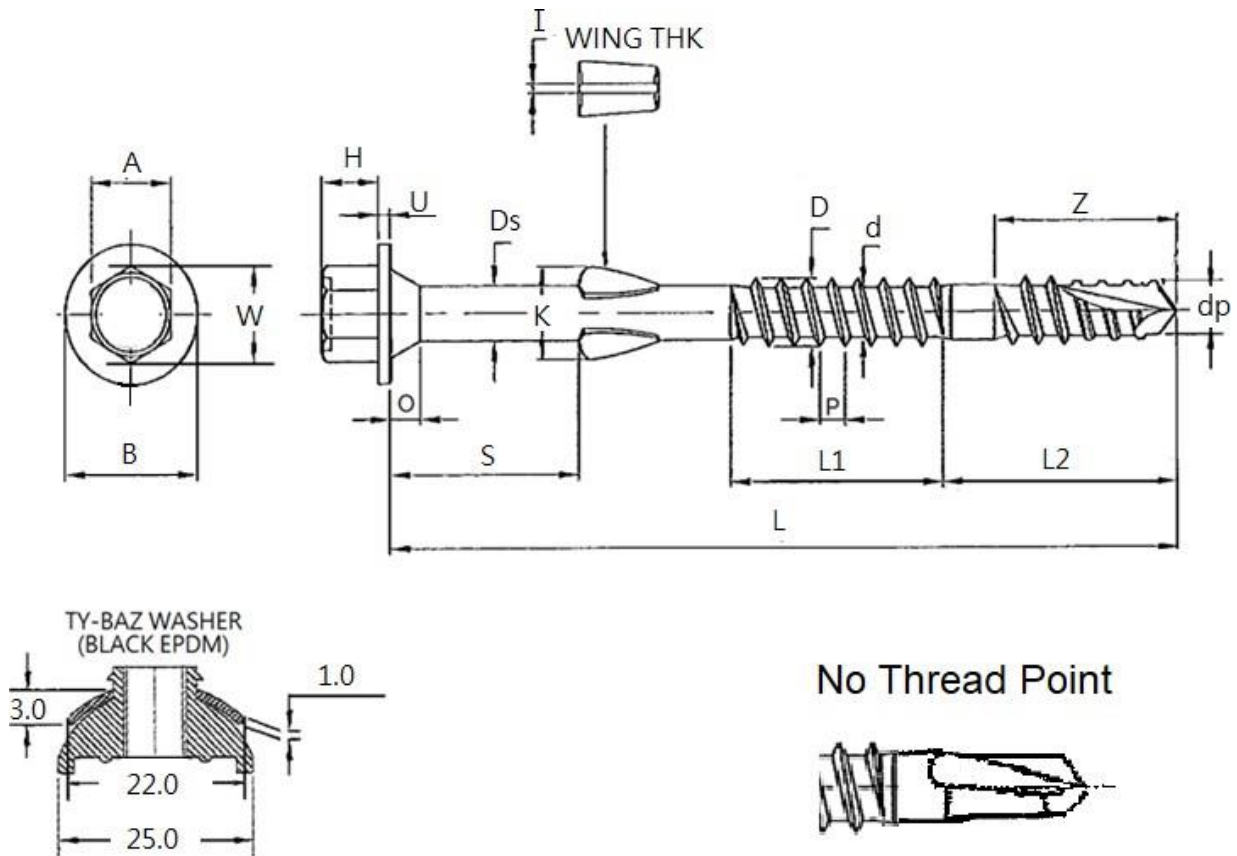

Unit: mm

Material: Stainless Steel (information kept at ETA-Denmark)

SIZE	A	W	B	H	U	O	Ds	K
M6.5	7.78	8.71	12.60	5.05	1.00	2.50 Ref	5.10 Ref	9.60
	8.00	Min	13.00	5.35	1.20			9.80
	I	D	d	P	Z	dp	L1	L2
	0.70	6.30	4.52	2.54 Ref	12.50 Ref	5.50	43.50	17.70
	1.00	6.50	4.70				46.50	20.70

Lt	min	44.50
	max	45.50
L		130.00

## Annex B Minimum distances and spacing

### Axially or laterally loaded screws in the plane or edge surface of cross laminated timber

Definition of spacing, end and edge distances in the plane surface:

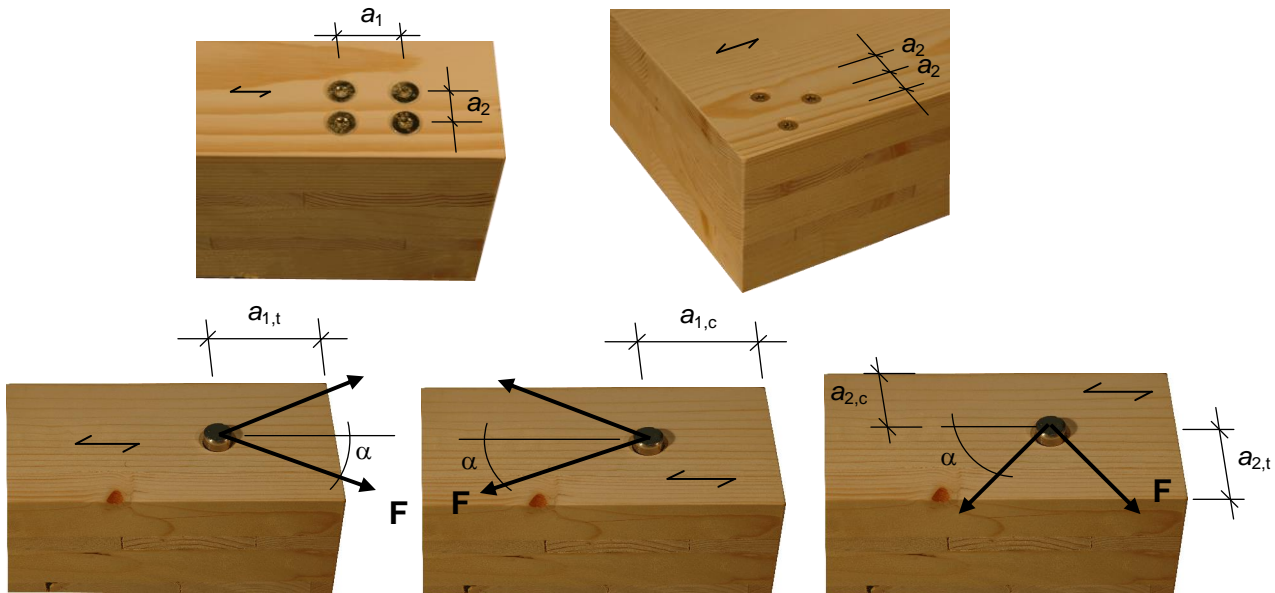

Definition of spacing, end and edge distances in the edge surface:

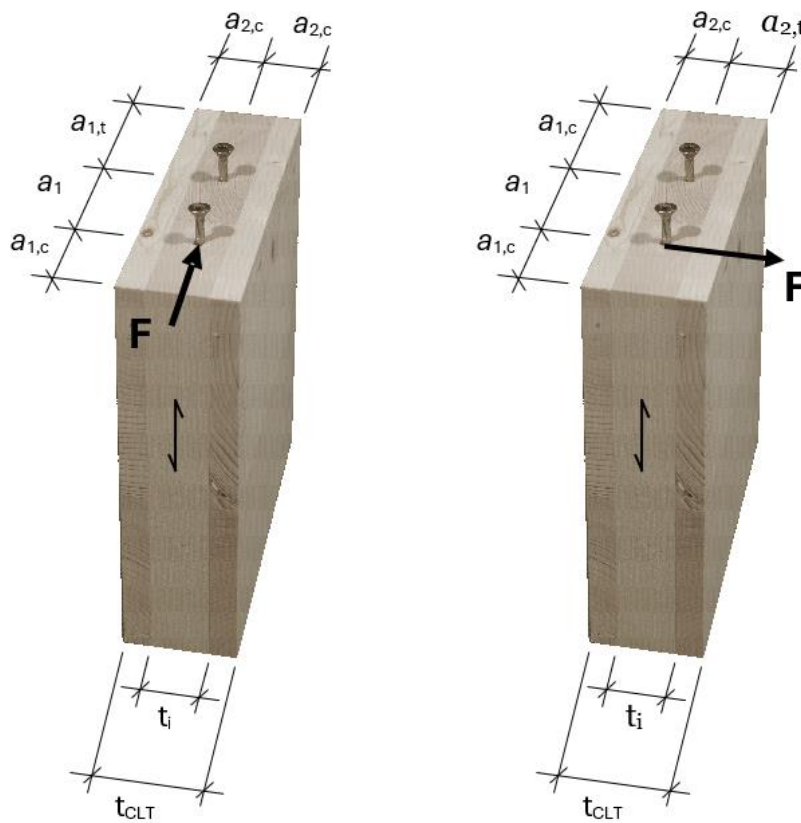

## Annex C

### Thermal insulation material on top of rafters

Nova Fastener screws with an outer thread diameter  $6 \text{ mm} \leq d \leq 12 \text{ mm}$  may be used for the fixing of thermal insulation material on top of rafters.

The thickness of the insulation shall not exceed 300 mm. The rafter insulation must be placed on top of solid timber or glued laminated timber rafters or cross-laminated timber members and be fixed by battens arranged parallel to the rafters or by wood-based panels on top of the insulation layer. The insulation of vertical facades is also covered by the rules given here.

Screws must be screwed in the rafter through the battens or panels and the insulation without pre-drilling in one sequence.

The angle  $\alpha$  between the screw axis and the grain direction of the rafter should be between  $30^\circ$  and  $90^\circ$ .

The rafter consists of solid timber (softwood) according to EN 338, glued laminated timber according to EN 14081, cross-laminated timber, or laminated veneer lumber according to EN 14374 or to European Technical Approval or similar glued members according to European Technical Approval.

The battens must be from solid timber (softwood) according to EN 338:2003-04. The minimum thickness  $t$  and the minimum width  $b$  of the battens is given as follows:

Screws  $d \leq 8,0 \text{ mm}$ :  $b_{\min} = 50 \text{ mm}$        $t_{\min} = 30 \text{ mm}$

Screws  $d \leq 10 \text{ mm}$ :  $b_{\min} = 60 \text{ mm}$        $t_{\min} = 40 \text{ mm}$

Screws  $d = 12 \text{ mm}$ :  $b_{\min} = 100 \text{ mm}$        $t_{\min} = 60 \text{ mm}$

The insulation must comply with a European Technical Approval. The thermal insulation material shall be applicable as insulation on top of rafters according to national provisions that apply at the installation site.

Friction forces shall not be considered for the design of the characteristic axial capacity of the screws.

The anchorage of wind suction forces as well as the bending stresses of the battens or the boards, respectively, shall be considered in design. Additional screws perpendicular to the grain of the rafter (angle  $\alpha = 90^\circ$ ) may be arranged if necessary.

The maximum screw spacing is  $e_s = 1,75 \text{ m}$ .

### Thermal insulation material on rafters with parallel inclined screws

#### Mechanical model

The system of rafter, thermal insulation on top of rafter and battens parallel to the rafter may be considered as a beam on elastic foundation. The batten represents the beam, and the thermal insulation on top of the rafter the elastic foundation. The minimum compression stress of the thermal insulation at 10 % deformation, measured according to EN 826<sup>1</sup>, shall be  $\sigma_{(10\%)} = 0,05 \text{ N/mm}^2$ . The batten is loaded perpendicular to the axis by point loads  $F_b$ . Further point loads  $F_s$  are from the shear load of the roof due to dead and snow load, which are transferred from the screw heads into the battens.

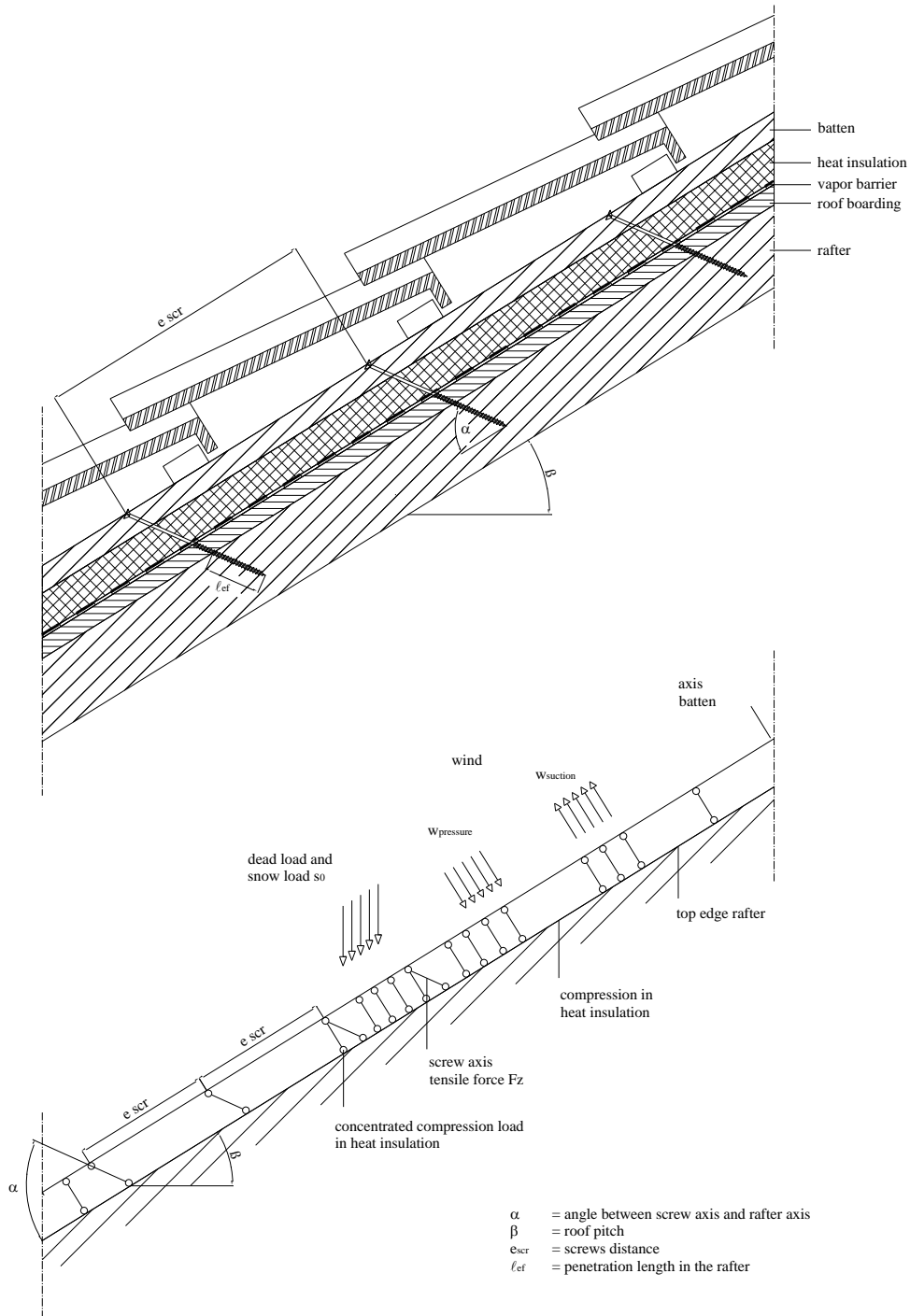

<sup>1</sup> EN 826:1996 Thermal insulating products for building applications - Determination of compression behaviour

### Design of the battens

The bending stresses are calculated as:

$$M = \frac{(F_b + F_s) \cdot \ell_{\text{char}}}{4}$$

Where

$$\ell_{\text{char}} = \text{characteristic length } \ell_{\text{char}} = \sqrt[4]{\frac{4 \cdot EI}{w_{\text{ef}} \cdot K}}$$

EI = bending stiffness of the batten

K = coefficient of subgrade

w<sub>ef</sub> = effective width of the thermal insulation

F<sub>b</sub> = Point loads perpendicular to the battens

F<sub>s</sub> = Point loads perpendicular to the battens, load application in the area of the screw heads

The coefficient of subgrade K may be calculated from the modulus of elasticity E<sub>HI</sub> and the thickness t<sub>HI</sub> of the thermal insulation if the effective width w<sub>ef</sub> of the thermal insulation under compression is known. Due to the load extension in the thermal insulation the effective width w<sub>ef</sub> is greater than the width of the batten or rafter, respectively. For further calculations, the effective width w<sub>ef</sub> of the thermal insulation may be determined according to:

$$w_{\text{ef}} = w + t_{\text{HI}} / 2$$

where

w = minimum width of the batten or rafter, respectively

t<sub>HI</sub> = thickness of the thermal insulation

$$K = \frac{E_{\text{HI}}}{t_{\text{HI}}}$$

The following condition shall be satisfied:

$$\frac{\sigma_{\text{m,d}}}{f_{\text{m,d}}} = \frac{M_{\text{d}}}{W \cdot f_{\text{m,d}}} \leq 1$$

For the calculation of the section modulus W the net cross section has to be considered.

The shear stresses shall be calculated according to:

$$V = \frac{(F_b + F_s)}{2}$$

The following condition shall be satisfied:

$$\frac{\tau_{\text{d}}}{f_{\text{v,d}}} = \frac{1,5 \cdot V_{\text{d}}}{A \cdot f_{\text{v,d}}} \leq 1$$

For the calculation of the cross section area the net cross section has to be considered.

### Design of the thermal insulation

The compressive stresses in the thermal insulation shall be calculated according to:

$$\sigma = \frac{1,5 \cdot F_b + F_s}{2 \cdot \ell_{\text{char}} \cdot w}$$

The design value of the compressive stress shall not be greater than 110 % of the compressive stress at 10 % deformation calculated according to EN 826.

### Design of the screws

The screws are loaded predominantly axially. The axial tension force in the screw may be calculated from the shear loads of the roof R<sub>s</sub>:

$$T_s = \frac{R_s}{\cos \alpha}$$

The load-carrying capacity of axially loaded screws is the minimum design value of the axial withdrawal capacity of the threaded part of the screw in the batten or rafter, the head pull-through capacity of the screw, where applicable and the tensile capacity of the screw.

In order to limit the deformation of the screw head for thermal insulation material thicknesses over 200 mm or with compressive strength below 0,12 N/mm<sup>2</sup>, respectively, the axial withdrawal capacity of the screws shall be reduced by the factors  $k_1$  and  $k_2$ :

$$F_{ax,\alpha,Rd} = \min \left\{ \frac{f_{ax,d} \cdot d \cdot \ell_{ef} \cdot k_1 \cdot k_2}{1,2 \cdot \cos^2 \alpha + \sin^2 \alpha} \cdot \left( \frac{\rho_k}{350} \right)^{0,8} ; f_{head,d} \cdot d_h^2 \cdot \left( \frac{\rho_k}{350} \right)^{0,8} ; \frac{f_{tens,k}}{\gamma_{M2}} \right\} \text{ for NOVA screws with smooth shank}$$

$$F_{ax,\alpha,Rd} = \min \left\{ \begin{array}{l} \frac{f_{ax,d} \cdot d \cdot \ell_{ef} \cdot k_1 \cdot k_2}{1,2 \cdot \cos^2 \alpha + \sin^2 \alpha} \cdot \left( \frac{\rho_k}{350} \right)^{0,8} \\ \frac{f_{ax,d} \cdot d \cdot \ell_{ef,b} \cdot k_1 \cdot k_2}{1,2 \cdot \cos^2 \alpha + \sin^2 \alpha} \cdot \left( \frac{\rho_k}{350} \right)^{0,8} \\ \frac{f_{tens,k}}{\gamma_{M2}} \end{array} \right\} \text{ for NOVA screws with double thread}$$

Where:

$f_{ax,d}$	design value of the axial withdrawal parameter of the threaded part of the screw
$d$	outer thread diameter of the screw
$\ell_{ef}$	Point side penetration length of the threaded part of the screw in the rafter, $\ell_{ef} \geq 40$ mm
$\ell_{ef,b}$	Length of the threaded part in the batten including the head [mm]
$\rho_k$	characteristic density of the wood-based member [kg/m <sup>3</sup> ]
$\alpha$	Angle between grain and screw axis ( $\alpha \geq 30^\circ$ )
$f_{head,d}$	design value of the head pull-through capacity of the screw
$d_h$	head diameter
$f_{tens,k}$	characteristic tensile capacity of the screw
$\gamma_{M2}$	partial factor according to EN 1993-1-1 or to the particular national annex
$k_1$	$\min \{ 1; 200/t_{HI} \}$
$k_2$	$\min \{ 1; \sigma_{10\%}/0,12 \}$
$t_{HI}$	thickness of the thermal insulation [mm]
$\sigma_{10\%}$	compressive stress of the thermal insulation under 10 % deformation [N/mm <sup>2</sup> ]

If  $k_1$  and  $k_2$  are considered, the deflection of the battens does not need to be considered. Alternatively to the battens, panels with a minimum thickness of 20 mm from plywood according to EN 636, particle board according to EN 312, oriented strand board according to EN 300 or European Technical Approval and solid wood panels according to EN 13353 or cross laminated timber may be used with screws with smooth shank under the head.